



1U Dual Slide 19" LCD Console Drawer with 16-port Cat6 KVM

Benefits

- ▶ 1U 19" LED-backlit LCD console drawer
- ▶ Dual slide - LCD and keyboard slide independently
- ▶ 1280 x 1024 native resolution / 16.7M colors
- ▶ Integrated with 16-port Cat6 IP KVM
- ▶ Cat6 dongle available for USB-C, DP, HDMI, DVI-D or VGA video input
- ▶ Port switching via OSD, membrane buttons & keyboard hotkeys
- ▶ Hot pluggable, no software or drivers required
- ▶ Cascade levels up to 8 KVM switches
- ▶ 104-key USB keyboard with touchpad
- ▶ One Man installation design
- ▶ Enhanced aesthetics with molded front handle and two point lock
- ▶ TAA Compliant

Product Specifications

KVM Port	
Port #	16
Connector	RJ-45
Connectivity	DP / HDMI / DVI-D / VGA dongle via Cat6 / Cat5 cable to server up to 40 meters (132 feet)
Resolution	16:9 - max. 1920 x 1080 16:10 - max. 1920 x 1200 4:3 - max. 1600 x 1200

LCD-backlit LCD Panel	
Panel size (diagonal)	19"
Native resolution	1280 x 1024
Brightness (cd/m ²)	250
Contrast ratio (typ.)	1000 : 1
Colors	16.7 M
Viewing angle (L/R/U/D)	85/85/80/80
Response time (ms)	5
Dot pitch (mm)	0.294
Display area (mm)	376.32H x 301.06V
Surface treatment	Haze 25%, Hard-coating
Surface hardness	3H
Backlight type	LED
MTBF (hrs)	30,000

Physical	
Product (W x D x H)	442 x 650 x 44 mm 17.4 x 25.6 x 1.73 inch
Packing (W x D x H)	590 x 815 x 140 mm 23.2 x 32.1 x 5.5 inch
Net weight	14.2 kg / 31.2 lb
Gross weight	20.4 kg / 44.9 lb

* All dimensions stated are subject to change if options are selected / integrated to base model part codes

IP Console	
Connector	RJ45
User management	1 x active user, 15-user login
Network protocol	DHCP / BOOTP / DNS
Security	TLS 1.3, AES, LDAP, Active Directory (AD), HTTP(s)
Resolution	16:9 - max. 1920 x 1080 (max. 50 m) 16:10 - max. 1920 x 1200 (max. 50 m) 4:3 - max. 1600 x 1200 (max. 100 m)

Power		
Input	Auto-sensing 100 to 240VAC, 50 / 60Hz	
Consumption	Screen on	Max. 55W
	Power saving mode	Max. 34W

Mounting Distance	
	660 ~ 870 mm 26 ~ 34.3 inch

Environment	
Operating temp.	0 to 55°C degree
Storage temp.	-20 to 60°C degree
Operating humidity	10~90%, non-condensing
Storage humidity	5 ~90%, non-condensing
Operating altitude	16,000 ft
Non-operating altitude	40,000 ft
Shock	10G acceleration (11ms duration)
Vibration	10~300Hz 0.5G RMS random vibration

Compliance	
EMC	FCC & CE
Safety	CE / LVD & UKCA
Environment	REACH & RoHS3 / WEEE

Standard Keyboard

Ge G keyboard with touchpad

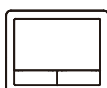
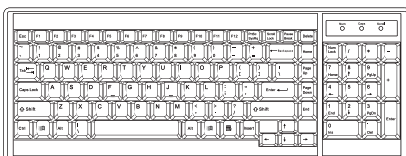

16-port Cat6 IP KVM I/O

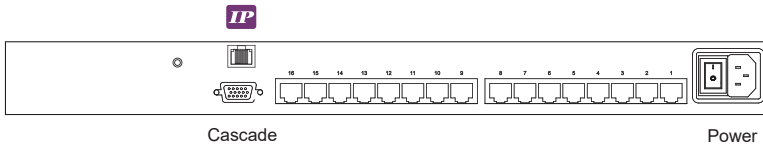

Cat6 KVM Dongles



KVM Port Connection

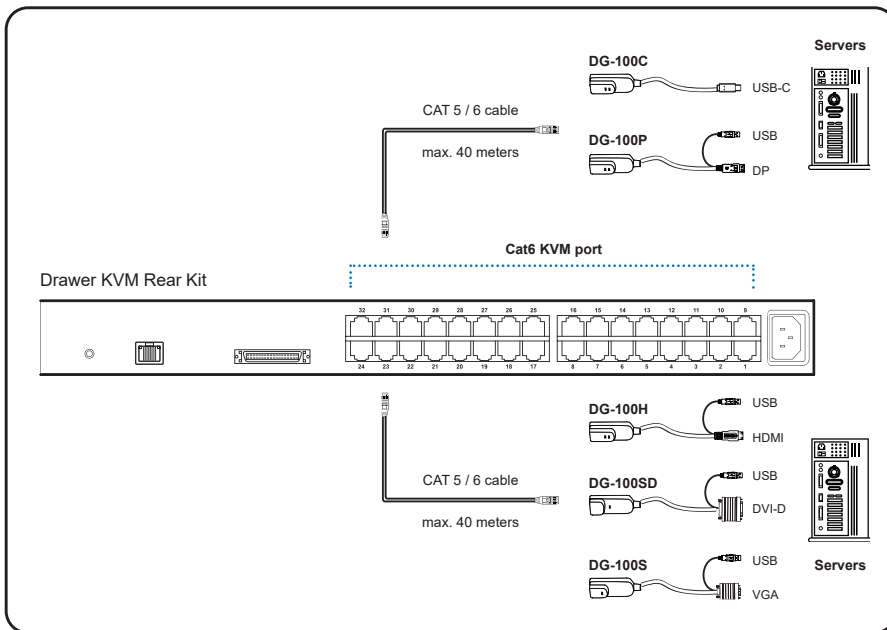

Cat6 Dongle

Resolution Support	Frequency (Hz)
1920 x 1200	60
1920 x 1080	60
1600 x 1200	60
1440 x 900	60
1280 x 1024	60
1024 x 768	60 / 70 / 75

IP Console Connection

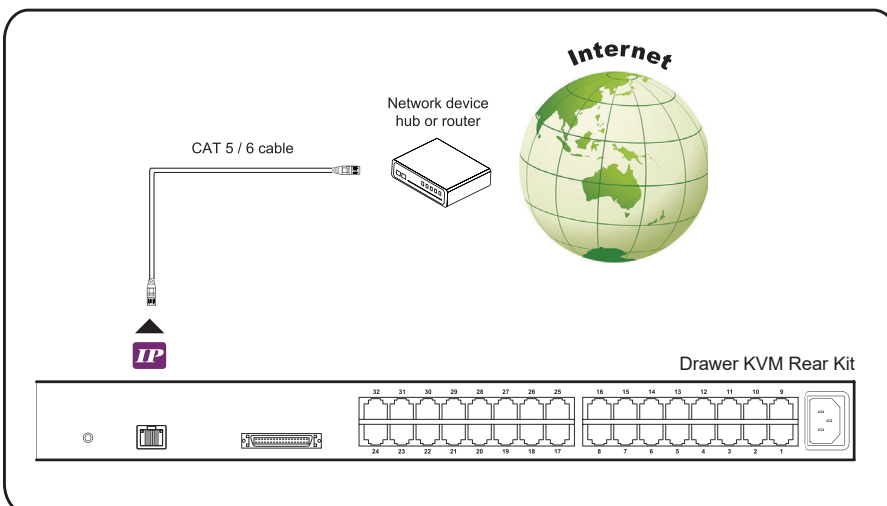

IP Console

Resolution Support	Frequency (Hz)
1920 x 1080	60
1920 x 1200	60
1600 x 1200	60
1280 x 1024	60
1024 x 768	60